

Title of a Paper to be presented at ETTC 2025

A. Author a¹, B. Author b², C. Author c¹, D. Author d³, E. Author e⁴, F. Author f⁴

1: Company1_name, Company1_address
2: Company2_name, Company2_address
3: Company3_name, Company3_address
4: Company4_name, Company4_address

Abstract: A Short Abstract (typically 50 words and no more than 300 words) should appear at first and precede the full text. The Short Abstract should clearly outline the objective, methodology and results of the contribution in order to provide a clear and useful summary for the reader.

Keywords: Paper format, instruction to authors

1. Introduction

The present file is to be used as a model for generating the full paper (max. 6 pages) to be presented at ETTC 2025.

2. Paper format

2.1 Format

The paper format should be as follows:

- the recommended size is 5 pages, maximum **6 pages**.
- Manuscripts must be typed on a 21 x 29.7 cm sized page (A4 format).
- Two columns per page. The columns should be justified to have straight left and right margins.
- The distance from the top edge of the paper to the top of the first line (i.e., the title) should be 30 mm. Left and right margins should be the same (16 mm). The width of each column should be 84 mm. The distance between the two columns of the text should be 10 mm. The distance from the bottom edge of the paper to the bottom of the last line of type on all pages should be no less than 26 mm; this allows room to insert page numbers.
- Do not paginate your paper. Page numbers will be inserted later by the Proceedings printer
- The text should begin at the top of the page.
- Typeface must be **Time New Roman** font, point-sized **10**.
- Use single spacing for the development.
- Major headlines are in bold type and centred. Ordinary headlines are placed on the left-hand margin on a separate line. Sub-headlines are underlined and start on the left-hand margin. The paragraph should start on the same line.

2.2 Organisation of the paper

Title: The title should be centred across the top of the first page and should be in Time New Roman 16 points. Avoid Block Letters in the Title.

Authors: The name of the author(s) should follow in Time New Roman 12. Company's addresses should then follow in Time New Roman 10 with cross-reference to the list of authors.

Keywords: authors must specify 3 to 5 keywords of their contribution to help targeting the main topics covered by the paper.

Text of the paper: The text of the paper begins right after the keywords with the first paragraph. The whole paper must be written in English.

Equations: Equations must be numbered sequentially. Equation number should be placed in the right-hand margin as follows:

$$a = b + c \quad [1]$$

Illustrations: Illustrations may be in colour provided that they appear clearly when printing in grey shades.

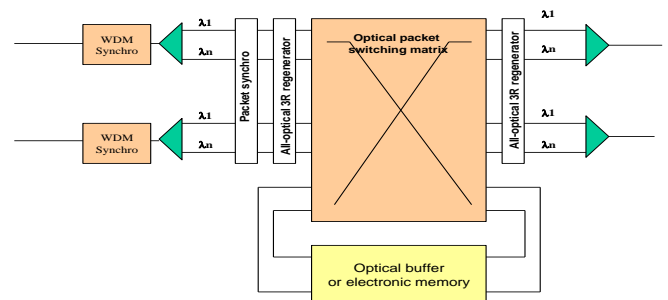

Figure 3: Structure of an all-optical packet router

Graphics and Pictures: These should be reduced to their proper size and inserted as close as possible to their reference in the text. All legends should be typed using the same point size as the rest of the text. Supply good quality original drawings, photographs or graphics integrated.

Tables: Tables must be centred and should have a short heading. Allow for extra spacing above and below the Table for clarity.

References: References should be cited, at the end of the paper, in numerical order in which they appear in the text.

When citing reference in the text, type the corresponding number in square brackets as shown at the end of this sentence [1]. See the recommended standard for the wording of references in the corresponding paragraph below.

Glossary: A glossary is expected to detail all acronyms to help the reader understand your paper.

Important: The text must not include any company logo. References to commercial companies or organisations should be restricted to what is strictly necessary (for the author's address, biography,..).

3. Paper submission

Please save this file in .pdf format as ETTC2025_ *authorname*.xxx where "authorname" is the name of the main author (preferably, the name of the speaker) in case of several authors, and xxx is "pdf".

The **full paper** (6 pages max) should be transmitted **before January 17th**, to the ETTC 2025 Conference Secretariat:

ettc2025@gmail.com

If you propose more than one paper, please add a hyphen and a number -1, -2, ... to the file name.

If you propose a modified version of an already proposed paper, please add similarly -V1, -V2, -V3, ... standing for "version 1", "version 2", ... to the file name.

Hot line: In case of difficulty in preparing your paper, please send an email to the ETTC 2025 Technical Secretariat: ettc2025@gmail.com

4. Full Paper Deadline

April 30, 2025: Submission deadline for full papers (max. 6 pages).

5. Conclusion

This paper has provided guidelines to submit full papers to ETTC 2025. Please make an effort to adhere to these guidelines as the quality of the Proceedings depends on you. Thank you for your cooperation and contribution.

It is highly recommended to use the present document as a model, and even as a starting point for your final paper, and send us back the resulting .pdf file.

We encourage you to send us your paper under .pdf format which you can easily generate by Acrobat, starting with your .doc file (if you do not have this possibility available, send only the .doc file and we will generate the .pdf file for you).

6. Acknowledgement

The authors acknowledge the contribution of their colleagues to this work.

6. References

- [1] Authors: "*Title of Book*", Chapter, and Page of the quote, Publisher, Year of publication.
- [2] Authors: "*Title of Paper*", Name of the Journal, Volume, Issue, Publisher, and Year of publication.
- [3] Authors: "*Title of Paper*", Name of the conference, Location (Town, Country), Year of conference.

7. Glossary

PDF: Portable Document Format

RTF: Rich Text Format